



# BMK-12

## Dual-Gard By-Pass Filter Mounting Kit Installation and Servicing Instructions

### IMPORTANT NOTICE

Read **all** instructions completely before attempting to install this unit. Improper installation could result in serious system and/or equipment damage. The installation of this system is not difficult, however, some mechanical ability is necessary. If you are not comfortable with the instructions or have questions, **do not attempt to install this system**. Consult a mechanic or contact AMSOIL INC. for further instructions or assistance.

**WARNING:** This filter system is **not** designed to replace the engine's normal full-flow filter. Do not attempt to install a by-pass filter element in place of the existing full-flow filter. This unit was designed for heavy duty and industrial equipment. For automotive and light duty truck applications consult your AMSOIL dealer for the proper filter mount.

**WARNING:** Extreme care should be taken to avoid bodily harm during installation. Before starting, ensure the engine is cool to avoid burns and **never** work in the engine compartment area with the engine running.

### A. Getting started

1. Check all parts against the parts list and inspect for damage.
2. Make sure you have the tools needed for the job.

#### Recommended tool list

|                    |               |                          |
|--------------------|---------------|--------------------------|
| 5/16" Allen wrench | Torque wrench | Drill                    |
| 7/16" wrench (2)   | Hammer        | 1/4" drill bit           |
| 7/8" wrench        | Center punch  | Adjustable filter wrench |
| 9/16" wrench       |               |                          |

3. Because of the wide range of possible mounting configurations, hose and hose fittings are not provided with this mount. Hose should meet or exceed SAE-100R6 specifications, and have a minimum inside diameter of 1/4". The mount itself has 3/4"-16 straight threads and the adapter fittings provided are 3/4"-16 straight x 1/4" JIC. Read through instructions and determine which plumbing arrangement best fits your application. Purchase hose and fittings accordingly. Make certain hose fittings match the type of hose chosen. **Note:** Hose and hose fittings are available from AMSOIL and your local AMSOIL dealer. Refer to diagram D and the parts list for 1/4" components matched for use with this system.

### B. Filter selection

Any of the 3 different sizes of the AMSOIL Spin-On By-Pass Oil Filter elements may be used with this mount. Select the element size according to your vehicle's oil capacity.

| Vehicle Oil Capacity | Recommended Element |
|----------------------|---------------------|
| 15 to 18 quarts      | use two EaBP-90     |
| 15 to 30 quarts      | use two EaBP-100    |
| 15 to 42 quarts      | use two EaBP-110    |

Service recommendations for these filters are listed later in these instructions. Selecting a larger filter than recommended will extend the service interval, while selecting a smaller filter than recommended will shorten the service interval.

### C. Attaching the filter mount

1. Survey the engine compartment for possible mounting locations. Solid structures such as the firewall, fender well, radiator support or frame are normal locations. Refer to diagram A for minimum area requirements and consider accessibility for servicing.
2. Note that the filter mount can be rotated 180° in its mounting brackets. This

allows the oil supply and return hoses to enter the mount on either the right or left hand side. Choose the side that will minimize the need for bends in the hoses or additional hose fittings. Refer to diagram B for preferred mounting positions.

3. When the location has been determined, use the mounting template provided to locate and mark mounting holes. This can be easily done with a center punch and hammer.
4. With a 1/4" drill bit, drill out the previously marked mounting holes and attach the two piece mount bracket. Use the 4 - 1" long 1/4" bolts, nuts, small washer and fender washers provided. Note the assembly diagram D for details. Using two 7/16" wrenches or socket, tightened to 8 foot pounds.
5. Apply thread sealant onto the "O" ring adapter fitting (BP-213) and the restrictor assembly (BP-202) as noted in diagram C. Install the "O" ring adapter fitting (BP-213) in the mount end adjacent to the arrows pointing **IN**. Install the restrictor assembly (BP-202) in the mount end adjacent to the arrow pointing **OUT**. Using a 7/8" wrench, tighten both fittings to 40-43 foot pounds.

**Warning:** The system is designed for partial/by-pass oil flow. Failure to install the restrictor assembly (BP-202) can result in serious equipment damage.

6. Apply thread sealant as noted in diagram C to the Allen head "O" ring plugs (BP-191). Using a 5/16" Allen head wrench, install plugs in remaining mount ports and tighten to 40-43 foot pounds. **Note:** If optional oil sampling valve is to be used, refer to diagram D and install in place of either Allen head "O" ring plug.
7. Attach the filter mount to the mounting brackets using 4-1 1/2" long 1/4" bolts, nuts and washers provided. **Warning:** The bolts **must be** installed so that the nuts are on the side opposite the filter nipples. Failure to do this will result in the bolts hitting the oil filters. Using two 7/16" wrenches or socket, tighten to 8 foot pounds.

### D. Oil Supply

1. Usable oil pressure sources are available on many engine blocks. There are openings into the oil channel through the side of the block and in the area of the existing oil filter (s). Make sure it is an oil pressure opening by replacing the plug with a gauge and turning the engine over, or by turning the engine over with the plug out and watching for increased flow. **DO NOT START ENGINE WITHOUT PREPARATION TO CONTROL THE OIL FLOW.** Install appropriate fitting to accept your hose connector.
2. An alternate installation is to use the existing oil pressure sending unit. Remove the oil pressure sending unit and install a street tee. Then re-install the sending unit in one arm of the tee. **Note:** With this installation a slightly lower oil pressure reading may register, indicating oil flow to the by-pass filter. A change of 10% or less is not to be considered significant.
3. Install selected hose and hose fittings between the engine block or the remaining arm of the tee and the filter mount port marked with the arrow pointing **IN**. Hose should be routed in a manner that avoids contact with sharp or moving parts and minimizes bends. If bends in the hose can not be avoided, make sure the bend is greater than the minimum radius recommended by the hose manufacturer. **Note:** Bends should not start at the fitting. Refer to diagram E for suggestions on proper hose routing.
4. To maintain hose position, plastic hose ties are advised.

### E. Oil Return

1. *Existing Porting Options:* Most engines have an oil return opening in the crankcase wall or oil pan, usually on the same side as the oil channel pressure opening but somewhat lower. Remove the plug and determine that it is not a

pressurized port and offers an unrestricted flow to the oil pan. Install the appropriate fitting to accept your hose fitting. Attach and route hose, connecting to the filter mount port marked with the arrow pointing **OUT**. This should be the same port in which you previously installed the restrictor assembly (BP-202).

2. **New Porting Option:** Where an installation requires a new hole (in oil pan or valve cover), a self-tapping hollow bolt may be used. (The bolt is available from AMSOIL. Order BP-40 Bolt and BP-41 Sealing Gasket.)

**Note:** The self-tapping hollow bolt should be used on stamped metal components only.

- For oil pan installation, mark a spot approximately 3" above the bottom of the pan. Avoid any pan formations that may suggest an internal obstruction. For the valve cover, choose a mounting location that will not interfere with the movement of internal components and away from the crankcase ventilation lines.
- Using a center punch and hammer, punch a hole in the chosen location between  $\frac{1}{4}$ " (.25") and  $\frac{5}{16}$ " (.3125") in diameter, **Note:** Do not drill this hole as metal fillings are likely to enter the engine and it will produce a weaker attachment of the self-tapping hollow bolt.
- Using a  $\frac{9}{16}$ " wrench, thread in the self-tapping hollow bolt (BP-40) and sealing gasket (BP-41). As the bolt is tightened, make sure sealing gasket is snug all the way around the bolt. Tighten bolt to 6-8 foot pounds.
- Install the appropriate fitting to accept your hose fitting. Attach and route hose, connecting to the filter mount port marked with the arrow pointing **OUT**. Again this should be the same port in which you previously installed the restrictor assembly (BP-202).

3. **Other Options:** Use a hollow bolt (available locally) to replace a cap screw holding such components as the fuel pump, timing case, or an inspection cover. Remove the selected bolt and determine if it provides an unrestricted passage to the oil pan. If so, install the hollow bolt. Route and connect hose as previously described. You may also use the AMSOIL Oil Return Swivel fitting (BP-89). See additional information on swivel fitting on last page.

4. Fill the selected AMSOIL By-Pass Filter elements with the same motor oil being used in the vehicle. Lubricate the filter gasket with oil and spin filters onto mount. Tighten one full turn after filter gasket first contacts mount, back off  $\frac{1}{8}$ ".

## F. Start up procedures

- Check that all fittings and hoses are securely attached, and that the hoses are routed properly.
- Check engine oil level. Fill to full mark if necessary.
- Set vehicle parking brake. With transmission in park/neutral start the engine and immediately check oil pressure. Note: Pressure may initially take a moment or two to rise.

**Caution:** Carefully check for leaks at fittings, hoses and mount. If leaks are observed, **STOP ENGINE IMMEDIATELY**, repair leaks and continue.

- After engine has warmed, shut off and re-check engine oil level. Fill as necessary.
- Record vehicle mileage/operating hours and date of installation.

## G. Periodic maintenance

- Periodic visual inspection of the fittings and hoses is recommended. Check for leaks, hose deterioration and cuts. Repair and/or replace as necessary.
- Properly sized, your AMSOIL By-Pass filters will last twice as long as your regular full-flow filters. It is recommended however, filters be changed using an oil analysis program.
- To change the filter elements:
  - Ensure engine is off and use caution as the engine, oil and filters may be hot and could result in an injury.
  - Using a filter wrench, remove the filter elements. Dispose of properly.
  - Clean the filter gasket contact areas on the mount with a clean lint free rag.
  - Lubricate the new filter gaskets with clean oil or grease.
  - Fill filters as full as possible with engine oil.
  - Screw on new filters, tighten one full turn after filter gasket contacts mount. Back off  $\frac{1}{8}$ ".
  - Start engine and check for leaks.
  - Check engine oil level, fill as needed.
  - Record vehicle mileage/operating hours for future reference.

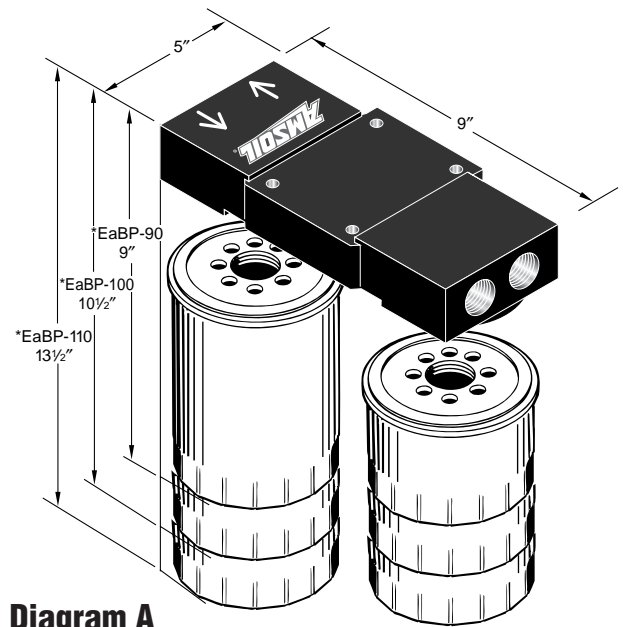

**Diagram A**

MINIMUM AREA NEEDED FOR  
DUAL MOUNT AND SPIN-ON OIL FILTER ELEMENTS

\* Mount and element heights plus 1-inch removal clearance

## Mounting Angle Diagram B

(Recommendations are the same right to left and front to back)  
Mounting angle above horizontal is not recommended

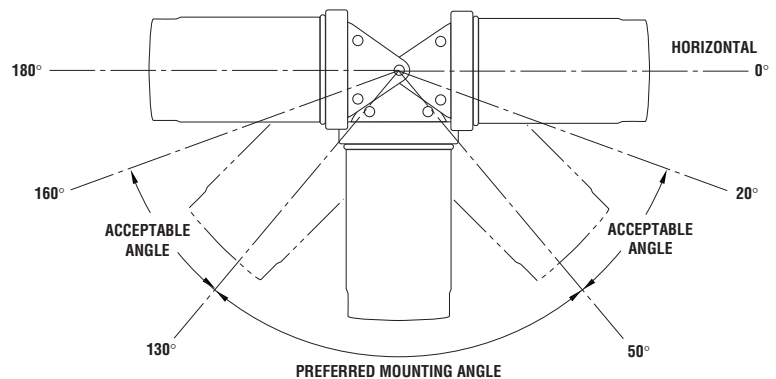

## Diagram C

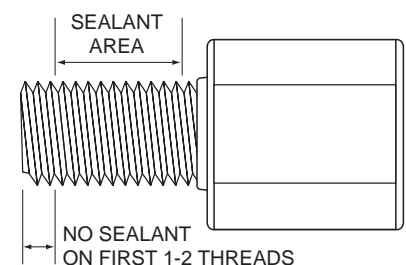

**Note:** If Teflon tape is used, it should be wrapped no more than  $1\frac{1}{2}$  to 2 turns in a clockwise direction when viewed from the thread end.

**Caution:** More than two turns of tape may cause distortion or cracking of the port. Never back off (loosen) pipe threaded connectors to achieve alignment.

## Mounting Template

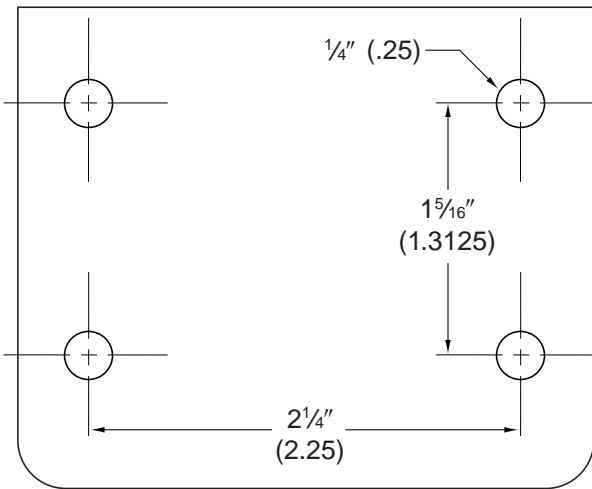

## Diagram D

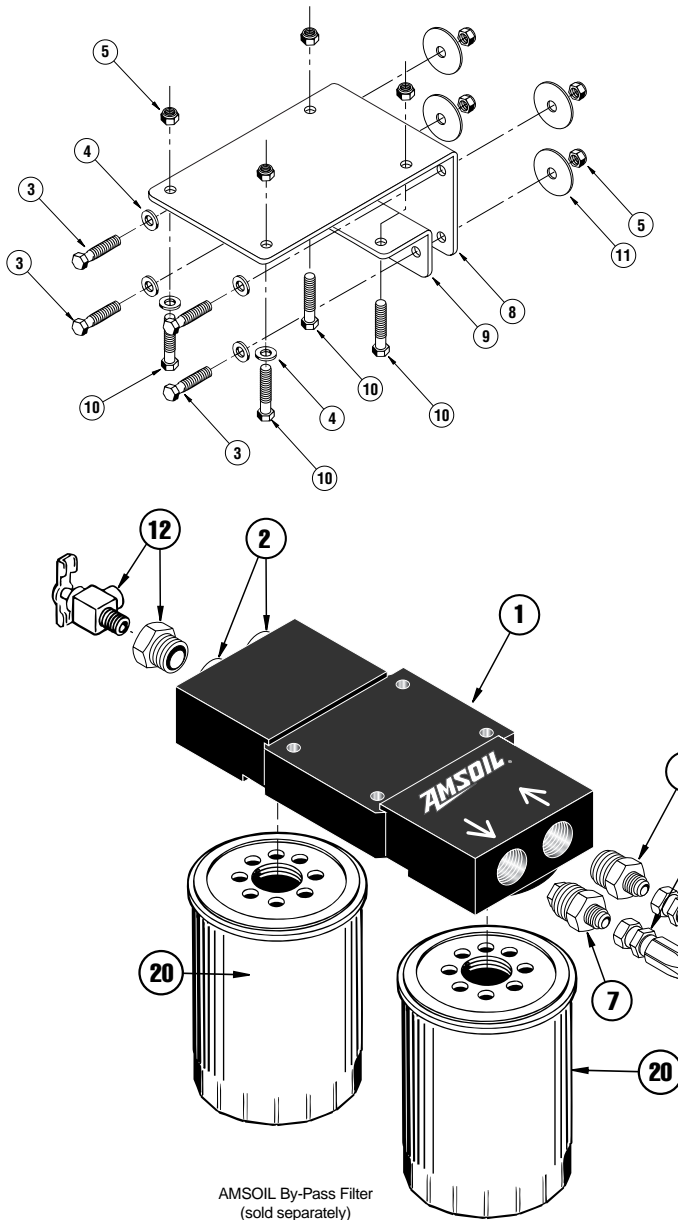

## Parts and assembly list

| Item | Description                                  | Qty. | Part No. |
|------|--|------|----------|
| 1.   | Filter Mount Assembly                        | 1    | BK-193   |
| 2.   | Allen Head Plug                              | 2    | BP-191   |
| 3.   | 1/4"-20x1" Hex Head Bolt                     | 4    | BP-23    |
| 4.   | 1/4" I.D. Washer                             | 6    | BP-21    |
| 5.   | 1/4"-20 Self Locking Nuts                    | 8    | BP-22    |
| 6.   | "O" ring Fitting Adapter 3/4"-16 to 1/4" JIC | 1    | BP-213   |
| 7.   | Restrictor Assembly (.092")                  | 1    | BP-202   |
| 8.   | Mounting Bracket (top)                       | 1    | BP-194   |
| 9.   | Mounting Bracket (bottom)                    | 1    | BP-195   |
| 10.  | 1/4"-20 x 1 1/2" Hex Head Bolt               | 4    | BP-185   |
| 11.  | 1/4" I.D. Fender Washer                      | 4    | BP-186   |
|      | Thread Sealant                               | 1    | BP-198   |
|      | Instruction Sheet                            | 1    | BP-137   |

Optional Parts Available From AMSOIL and Your AMSOIL Dealer.

|     |                                      |          |
|-----|--------------------------------------|----------|
| 12. | Oil Sampling Kit                     | BK-13    |
| 13. | Street "T" (1/8 x 1/8 x 1/8)         | BP-33    |
| 14. | 90° Street Elbow, 1/8"               | BP-52    |
| 15. | Fitting Adapter 1/8" npt to 1/4" JIC | BP-208   |
| 16. | Hose Fitting                         | BP-207   |
| 17. | Hose 1/4" I.D.                       | BP-216   |
| 18. | Sealing Gasket                       | BP-41    |
| 19. | Self Tapping Hollow Bolt             | BP-40    |
| 20. | Filter Elements (sold separately)    |          |
|     | 5.78" long filter element            | EaBP-90  |
|     | 7.25" long filter element            | EaBP-100 |
|     | 10.44" long filter element           | EaBP-110 |

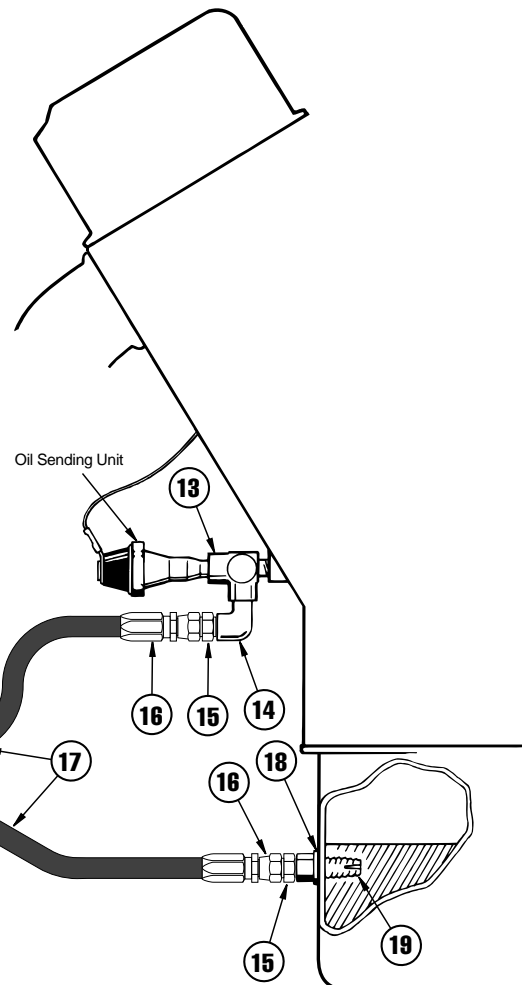

# Diagram E

## 1. Provide for length change

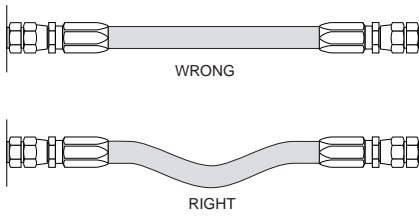

In straight hose installations allow enough slack in the hose line to provide for changes in length that will occur when pressure is applied. This change in length can be from +2% to -4%.

## 2. Avoid twisting and orient properly

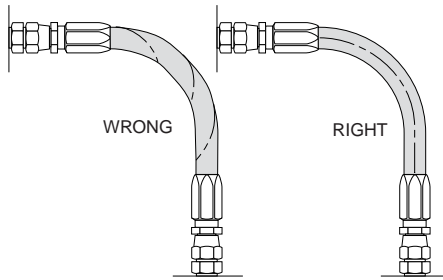

Do not twist hose during installation. This can be determined by the printed layline on the hose. Pressure applied to a twisted hose can cause hose failure or loosening of connections.

## 3. Protect from hazardous environment

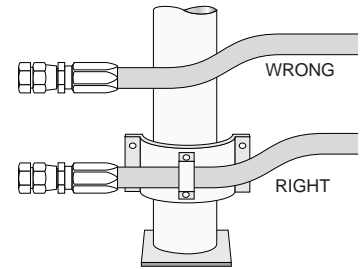

Keep hose away from hot parts. High ambient temperatures will shorten hose life. If you can not route it away from the heat source, insulate it.

## 4. Avoid mechanical strains

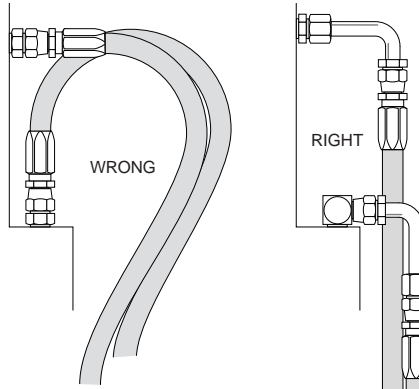

Use elbows and adapters in the installation to relieve strain on the assembly, and to provide easier and neater installations that are accessible for inspection and maintenance.

## 5. Use proper bend radius

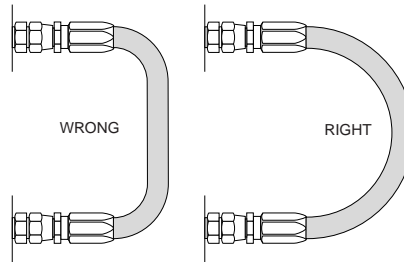

Keep the bend radius of the hose as large as possible to avoid collapsing of the hose and restriction of flow. Follow catalog specs on minimum bend radii.

## 6. Use proper bend radius (cont.)

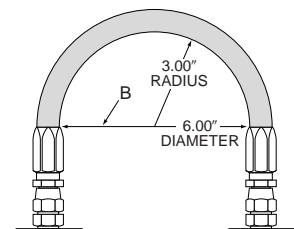

Maximum bend radius is measured on the inside bend of the hose. To determine minimum bend, divide the total distance between ends (B length) by 2. For example  $8 = 6$ , minimum bend radius = 3.

## 7. Secure for protection

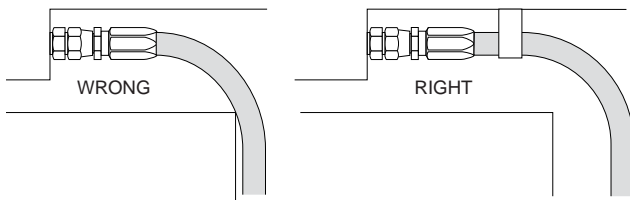

Install hose runs to avoid rubbing or abrasion. Use clamps to support long runs of hose or to keep hose away from moving parts. It is important that the clamps do not allow the hose to move. This movement will cause abrasion and premature hose failure.

## 8. Avoid Improper Hose Movement

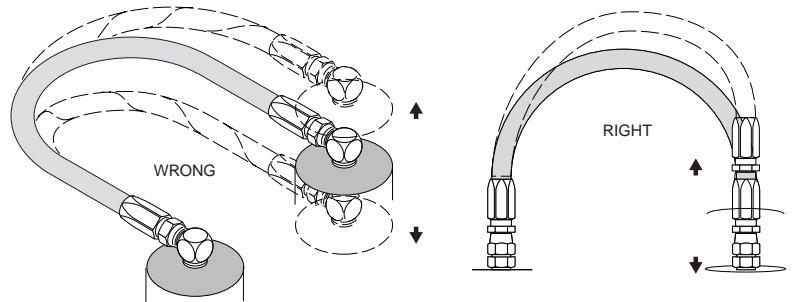

Make sure relative motion of the machine components produces bending rather than twisting of the hose. Hose should be routed so that the flex is in the same plane as the equipment movement.

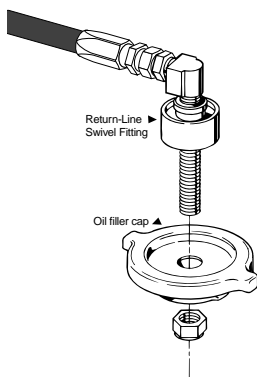

### BY-PASS OIL FILTER RETURN-LINE FITTING:

A swivel fitting can be installed directly on your oil filter cap for the oil return-line from the AMSOIL By-Pass Filter. This fitting can be used (in most cases) instead of the self-tapping hollow bolt, which is usually installed on the oil pan.

The Return-Line Fitting is made of a sturdy brass-alloy and is constructed so that the top of the fixture can swivel. This makes it easy to take off your oil cap. The installation of the fitting is simple and generally takes 5-10 minutes. Order BP-89. Be sure there is not a crankcase vent in this area.

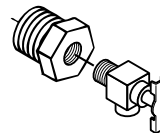

### INSTALLING AN OIL SAMPLING PETCOCK ON THE SPIN-ON BY-PASS:

Getting a clean and uncontaminated oil sample is easy and simple when an oil sampling pet-cock is installed into the Spin-On By-Pass Oil Filter system. This can be easily done by ordering a BK-13.

# BMK-12 PARTS IDENTIFICATION SHEET

(6) BP-21  
1/4" I.D. WASHER

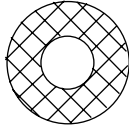

(1) BP-194  
MOUNTING  
BRACKET  
TOP

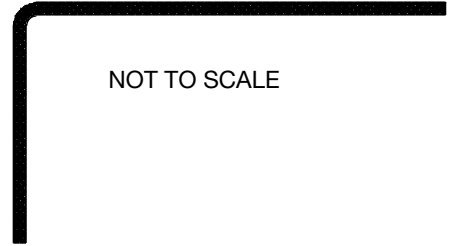

NOT TO SCALE

(8) BP-22  
1/4" NUT



(1) BP-195  
MOUNTING  
BRACKET  
BOTTOM



NOT TO SCALE

(4) BP-23  
1/4" X 1" BOLT

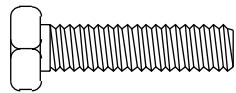

(4) BP-185  
1/4" X 1 1/2"  
BOLT

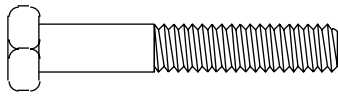

(1) BP-202  
RESTRICTOR  
ASSEMBLY

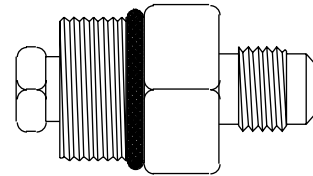

(4) BP-186  
1/4" FENDER  
WASHER

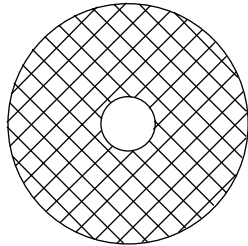

(1) BP-213  
"O" RING  
FITTING  
ADAPTER

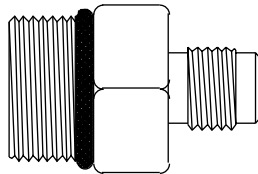

(1) BP-191  
ALLEN HEAD  
PLUG

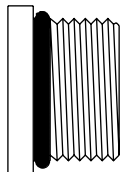

(1) BK-193  
FILTER MOUNT  
ASSEMBLY

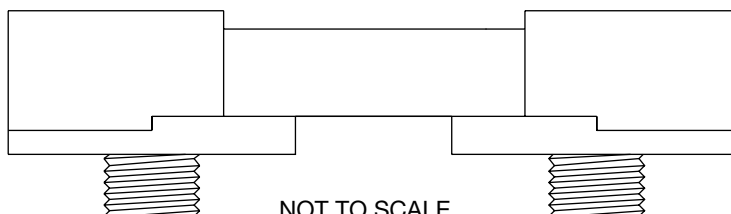

NOT TO SCALE